

EXPLODED VIEW

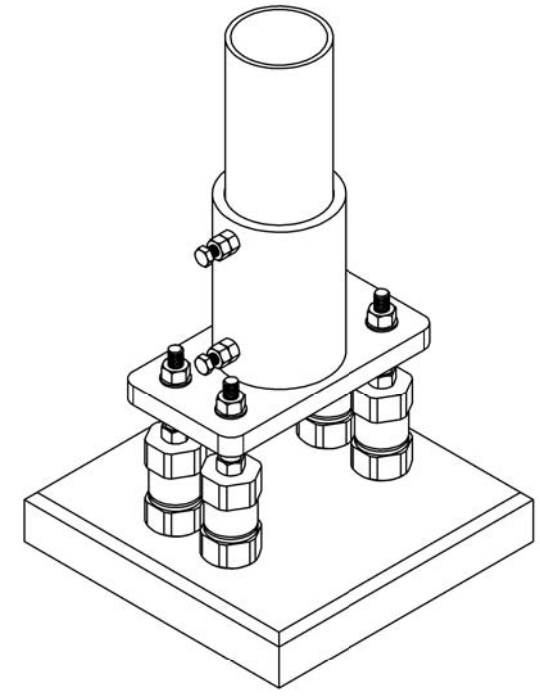

ISOMETRIC VIEW

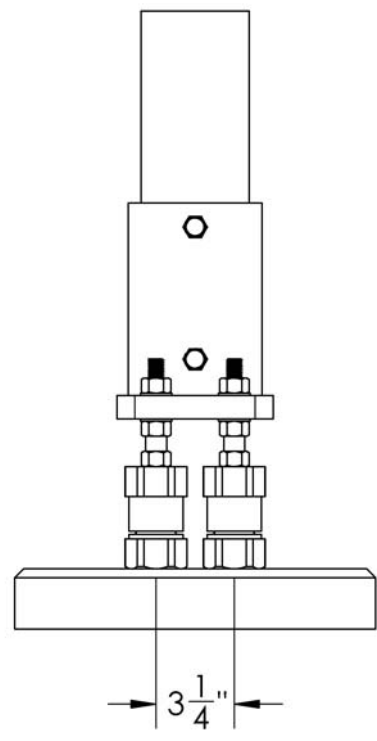

BACK VIEW

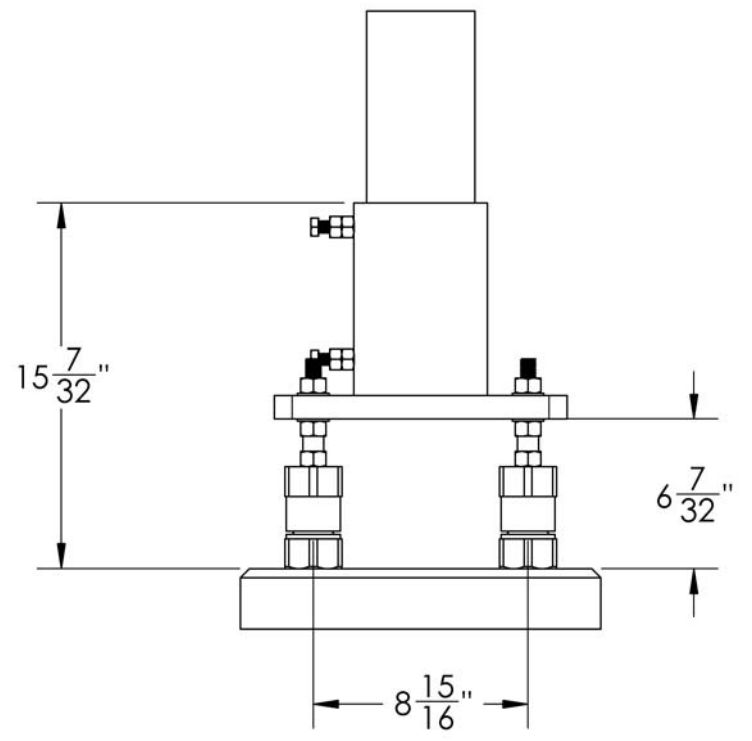

SIDE VIEW

ITEM NO.	PART NO.	DESCRIPTION	QTY.	MATERIAL
1	M26	5/8" NOM. GALV. FLAT WASHER	8	ASTM F436
2	M27	5/8"-11 UNC GALV. HEAVY HEX NUT	12	ASTM A194 GR 2H
3	M28	PLASTIC SPACER	4	HDPE
4	M25	5/8"-11 UNC GALV. STUD X 6" LG.	4	ASTM A193 GR. B7
5	C10S	C10S COUPLING	4	GRAY CAST IRON
6	M56	1/2" - 13 UNC HEX HD GALV BOLT X 2" LG.	2	ASTM A449
7	M24	1/2"-13 UNC GALV. HEAVY HEX NUT	2	ASTM A194 GR 2H
8		CONCRETE BASE WITH ANCHORS	1	
9		SIGN POST	1	
10	RPBP-4	4" NOM BASE PLATE ASSEMBLY	1	

NOTE: REFER TO SAFETY BASE INSTALLATION INSTRUCTIONS

DO NOT SCALE THIS DRAWING

PROPRIETARY AND CONFIDENTIAL

THE INFORMATION CONTAINED IN THIS DRAWING IS THE SOLE PROPERTY OF SAFETY BASE LTD.. ANY REPRODUCTION IN PART OR AS WHOLE WITHOUT THE WRITTEN PERMISSION OF SAFETY BASE LTD. IS PROHIBITED.

REV.	DESCRIPTION	APPROVED	DATE
-	ISSUED FOR CONSTRUCTION		OCT 7/10
A	ISSUED FOR INTERNAL REVIEW		JUL 17/09

NAME: MB DATE: JUL 17/09

DRAWN: MB

CHECKED:

TOLERANCES UNLESS SPECIFIED

FRACTIONAL ± 1/32"

DECIMAL ± .02"

THREE PLACE DECIMAL ± .002"

ANGULAR ± 1°

DIMENSIONS INCHES

SCALE: 1:8

SAFETY BASE LTD.

4" Nom. Round Post Support

General Assembly

Male Anchor Installation

FILE No.: T001 04 03

SIZE **B** DWG. NO. **SB502-3** SHEET 1 OF 1

REV. -