

SAFETY BASE INSTALLATION WITH REACTION PLATE

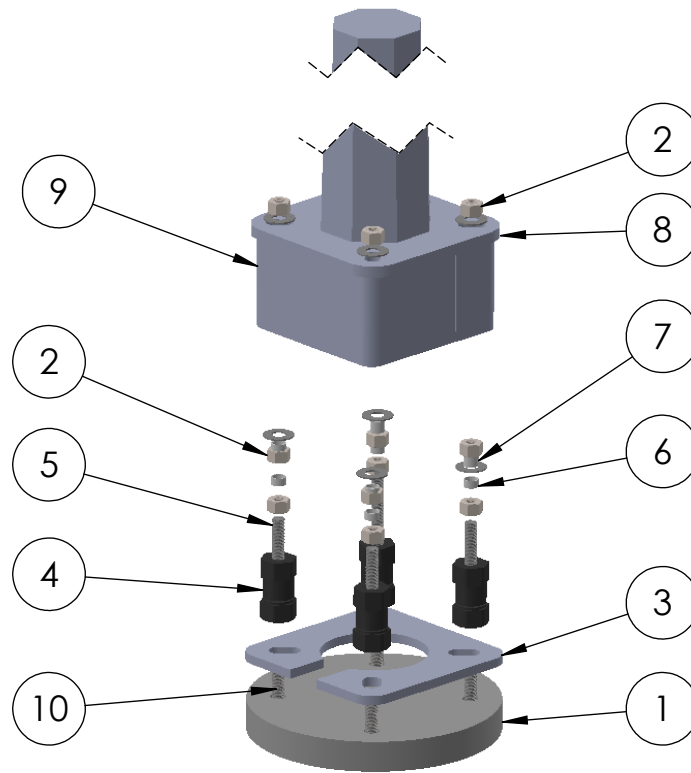

Standard Safety Base Installation Instructions All Anchor Bolt Sizes - With Reaction Plate

The following installation instructions are applicable to new installations or existing installations where appropriate anchor bolts have been cast into the concrete base support

Procedure

1. Clean the top surface of the concrete base and ensure surface is flat and level with no spalling or other surface conditions that may affect the performance of the installation.
2. Install the lower leveling nuts and the reaction plate.
3. Measure the height of the threaded anchor bolts above the reaction plate and ensure this measurement is between 1 1/4 and 1 5/8 inches.
4. It is recommended that the threaded anchor bolt-coupler connection be coated with a rust-inhibiting grease. This will facilitate removal of the coupler when it is necessary. A suitable product for this application is ARCAN 1, a white, water resistant grease marketed by IMPERIAL OIL LTD
5. (Continued on next Page)

STANDARD SAFETY BASE INSTALLATION



LAST UPDATED 7/27/2022

SAFETY BASE INSTALLATION WITH REACTION PLATE

(Continued from previous page)

5. Thread the coupler assembly on each anchor bolt (if the coupler assembly upper stud becomes loose as a result of handling, ensure that the stud is engaged at least 1 1/2" but not more than 1 3/4" in the coupler before locking with the lock nut).
6. Snug tight up each coupler against the reaction plate. Tighten each coupler alternately and incrementally, by means of a wrench or a pipe wrench on the **BOTTOM** hex of the coupler.
Note: Tightening the coupler on the top hex may weaken the coupler at the machined groove.
7. Bring the leveling nuts (and hence, the lower washers) into a level plane as desired making certain that at least one plastic spacer remains in contact with its leveling nut and its lock nut.
8. Place the pole base over the protruding studs, and secure the pole with the upper washers and retaining nuts.
9. With the pole in the required vertical orientation, and before final tightening, ensure that all leveling nuts, retaining nuts and upper and lower washers are made snug against the pole base plate.
10. Snug tighten the retaining nuts.
11. Make the necessary wiring connections, and install the protective shroud.

ITEM NO.	PART NUMBER	DESCRIPTION	QTY.
1	BASE	BY OTHERS	1
2	M06	1"-8 UNC x GALV HEAVY HEX NUT	12
3	RP-X	REACTION PLATE (OPTIONAL)	1
4	C10X	C10 COUPLER ASSEMBLY	4
5	M-X	1"-8 UNC x GALV STUD	4
6	M05	HDPE SPACER	4
7	M-X	1" GALV. WASHER	8
8	POLE	BY OTHERS	1
9	S-X	SHROUD (OPTIONAL)	1
10	-	ANCHOR BOLT - BY OTHERS	4

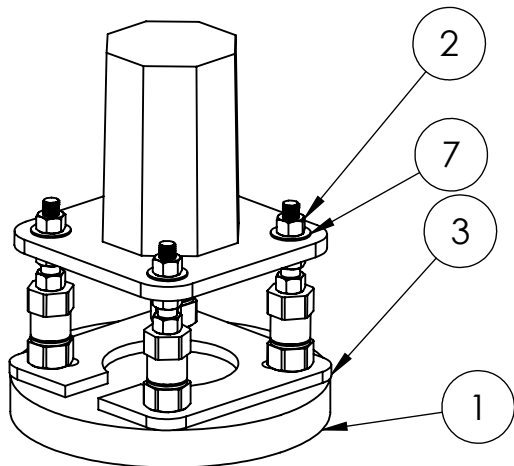

STANDARD SAFETY BASE INSTALLATION



LAST UPDATED 7/27/2022